

48-Kin  
TYPE SPECIMEN  
P1/16

UPPER & LOWERCASE  
TEXT & DISPLAY SERIF  
REGULAR

ILOTT-TYPE

48-Kin

ilott-type.com  
ilottvintage.com  
info@ilottvintage.com  
© 2015-16 ILOTT Vintage

A B C D E F G H I J K L M N O P Q R S T U V W X Y Z

a b c d e f g h i j k l m n o p q r s t u v w x y z

Á Â Ã Ä Å Æ Ç Ð É Ê Ë Ì Í Î Ï Ñ

Ó Ô Õ Ö Ø Ù Ú Û Ü Ý Þ ß à á â ã

ä å æ ç è é ê ë ì í î ï ð ñ

ó ô õ ö ø ù ú û ü ý þ ÿ

0 1 2 3 4 5 6 7 8 9

\* \ . : ; ! # \$ % & ' ( ) \_ { } [ ] ^ ~

€ ¥ £ ¤ | @ & ¶ © ® § ™ ° ˆ † ‡

ˆ ˇ ˘ ˙ ˚ ˛ ˜ ˝ ˞ ˜

48-Kin  
TYPE SPECIMEN  
P3/16

UPPERCASE

ILOTT-TYPE

A B C D  
E F G H I J K  
L M N O P  
Q R S T  
U V W X Y Z

ilott-type.com  
ilottvintage.com  
info@ilottvintage.com  
© 2015-16 ILOTT Vintage

48/60pt

48-Kin  
TYPE SPECIMEN  
P4/16

LOWERCASE

ILOTT-TYPE

abcd  
efghijkl  
lmnop  
qrst  
vwxyz

48-Kin  
TYPE SPECIMEN  
P5/16

FIGURES

ILOTT-TYPE

0123456789

ilott-type.com  
ilottvintage.com  
info@ilottvintage.com  
© 2015-16 ILOTT Vintage

Lining/Proportional  
72pt

48-Kin  
TYPE SPECIMEN  
P6/16

DIACRITICS



ILOTT-TYPE

PUNCTUATION  
& SYMBOLS

ILOTT-TYPE

\* \ . : ; , . . . ! ! # ? j " " ' / \_ { } [ ] ( ) — — — — « » « » « »  
€ ¤ \$ € £ ¥ ¤ | @ & ¶ © ® § ™ ° ^ † ‡

48-Kin  
TYPE SPECIMEN  
P8/16

VECTOR PATHS

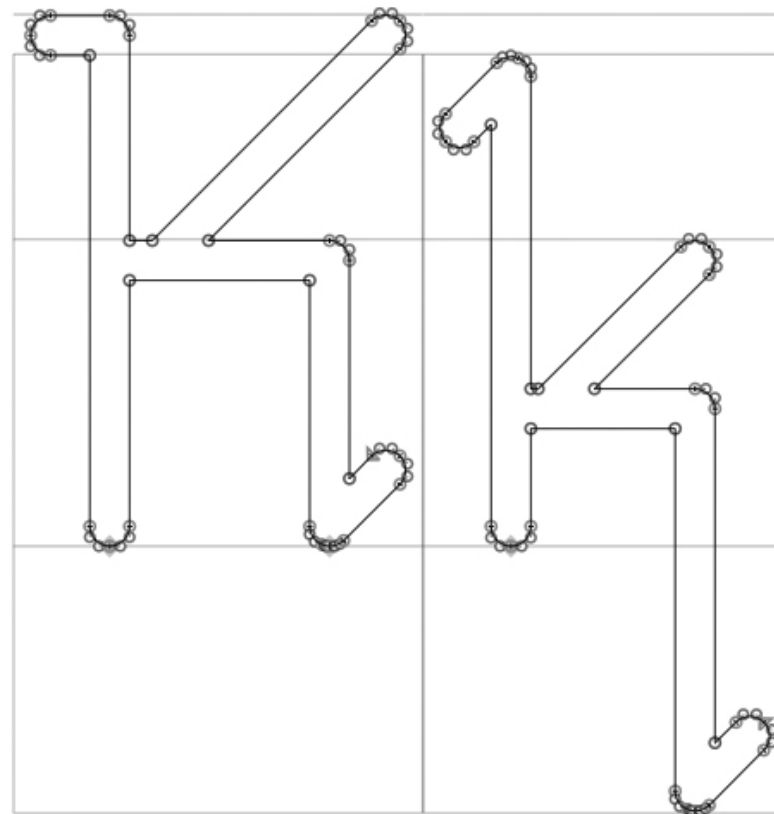

ILOTT-TYPE



48-Kin  
TYPE SPECIMEN  
P9/16

SAMPLES

ILOTT-TYPE

Final four

ilott-type.com  
ilottvintage.com  
info@ilottvintage.com  
© 2015-16 ILOTT Vintage

90pt

48-Kin  
TYPE SPECIMEN  
P10/16

SAMPLES

ILOTT-TYPE

{, "2&P/Straf3e\9623"?}

ilott-type.com  
ilottvintage.com  
info@ilottvintage.com  
© 2015-16 ILOTT Vintage

40pt

48-Kin  
TYPE SPECIMEN  
P11/16

SAMPLES

ILOTT-TYPE

apfel

ilott-type.com  
ilottvintage.com  
info@ilottvintage.com  
© 2015-16 ILOTT Vintage

150pt

48-Kin  
TYPE SPECIMEN  
P12/16

SAMPLES

ILOTT-TYPE

BluePrint

ilott-type.com  
ilottvintage.com  
info@ilottvintage.com  
© 2015-16 ILOTT Vintage

70pt

48-Kin  
TYPE SPECIMEN  
P13/16

SAMPLES

ILOTT-TYPE

La composition doit être une de nos  
préoccupations constantes, mais au  
moment de photographier elle ne peut  
être qu'intuitive, car nous sommes aux  
prises avec des instants fugitifs où les  
rapports sont mouvants.

48-Kin  
TYPE SPECIMEN  
P14/16

SAMPLES

ILOTT-TYPE

ilott-type.com  
ilottvintage.com  
info@ilottvintage.com  
© 2015-16 ILOTT Vintage

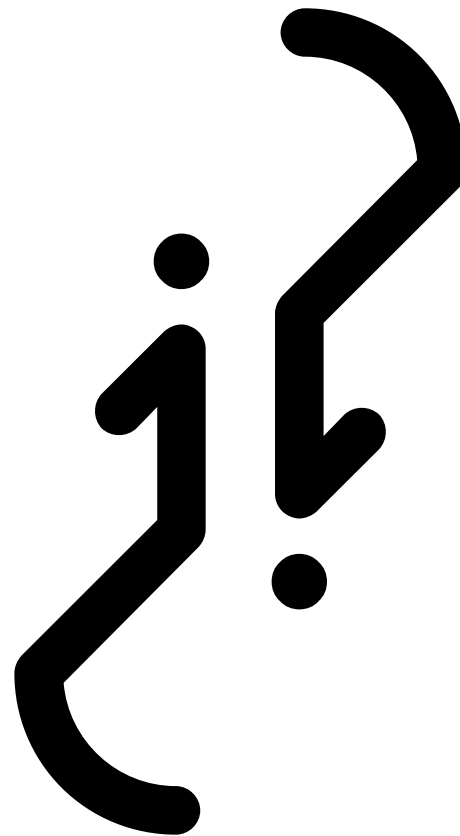

260pt

48-Kin  
TYPE SPECIMEN  
P15/16

INSPIRATION

ILOTT-TYPE



ilott-type.com  
ilottvintage.com  
info@ilottvintage.com  
© 2015-16 ILOTT Vintage

1948-c.1959

48-Kin  
TYPE SPECIMEN  
P16/16

ILOTT-TYPE



Konica

ilott-type.com  
ilottvintage.com  
info@ilottvintage.com  
© 2015-16 ILOTT Vintage