

57-nao
TYPE SPECIMEN
P1/16

UPPER & LOWERCASE
MONOSPACE
REGULAR

ILOTT-TYPE

57 - nao

ilott-type.com
ilottvintage.com
info@ilottvintage.com
© 2015-16 ILOTT Vintage

ABCDEFGHIJKLMNOPQRSTUVWXYZ

abcdefghijklmnopqrstuvwxyz

ÁĂÄÅÀĀĂĄÃǼĆČǾĐĎĎÉĚĔĚĚÈĒĘĞıĭİİıĬĴĸŁŁĹĽŁĻŃŅŇŃ

ÓÔÏÖÕŎØȮȰŔŖŔŖŞŞŞŦŦŦÛŪŪÛŮŮŮŰŴŴŴŶŶŶÝŸŸŸŽŽŽ

áăâãäåàāăąãǽćčǿđďďéěĕĕĕèēęğııİİİİıİİĴĴĴĴĻĻĻĻŃŃŃŃ

óôöòóõøȯȱŕŕŕŕşşşşŧŧŧŧűűűűűüüüüüŰŰŰŰŰŴŴŴŴŶŶŶŶŶŶŶŶŸŸŸŸŹŹŹ

0123456789

* \ . • : , … ¡ ! # . ? ¿ ” ’ ; / _ { } [] () - - - « » ‹ › “ ” ‘ ’

¢ ₣ \$ € £ ¥ ≈ ~ ÷ ø = > ≥ ∞ ∫ < ≤ ¬ - × ≠ ∂ ‰ ‰ ± ∏ √ ∑ ∏ ∣ ∣ @ & ¶ © ® § ™ ° ^ † ‡

˘ ˙ ˚ ˛ ˜ ˝ ˞ ˟ ˠ ˡ ˣ ˤ ˥ ˦ ˧ ˨ ˩ ˪ ˫ ˬ ˭ ˮ ˯ ˰ ˱ ˲ ˳ ˴ ˵ ˶ ˷ ˸ ˹ ˺ ˻ ˼ ˽ ˾ ˿

57-nao
TYPE SPECIMEN
P3/16

UPPERCASE

ILOTT-TYPE

A B C D E F G
H I J K L M N
O P Q R S T
U V W X Y Z

ilott-type.com
ilottvintage.com
info@ilottvintage.com
© 2015-16 ILOTT Vintage

72/86pt

57-nao
TYPE SPECIMEN
P4/16

LOWERCASE

ILOTT-TYPE

a b c d e f g
h i j k l m n
o p q r s t
u v w x y z

ilott-type.com
ilottvintage.com
info@ilottvintage.com
© 2015-16 ILOTT Vintage

72/86pt

57-nao
TYPE SPECIMEN
P5/16

FIGURES

ILOTT-TYPE

0 1 2 3 4 5 6 7 8 9

ilott-type.com
ilottvintage.com
info@ilottvintage.com
© 2015-16 ILOTT Vintage

Lining/Tabular
62pt

57-nao
TYPE SPECIMEN
P6/16

DIACRITICS

ILOTT-TYPE

ˊ ˋ ˌ ˍ ˎ ˏ ː ˙ ˚ ˛ ˜ ˘ ˙ ˚ ˛

PUNCTUATION
& SYMBOLS

ILOTT-TYPE

* \ . • : , … ¡ ! # . ? ¿ " ' ; / _
{ } [] () — — — « » < > “ ” ‘ ’
¢ ¤ \$ € £ ¥ ≈ ~ ÷ ∅ = > ≥ ∞ ∫ < ≤ ¬ -
× ≠ ∂ ‰ ‰ + ± ∏ √ ∑ ∅ | | @ & ¶ © ® § ™ ° ^ † ‡

57-nao
TYPE SPECIMEN
P8/16

VECTOR PATHS

ILOTT-TYPE

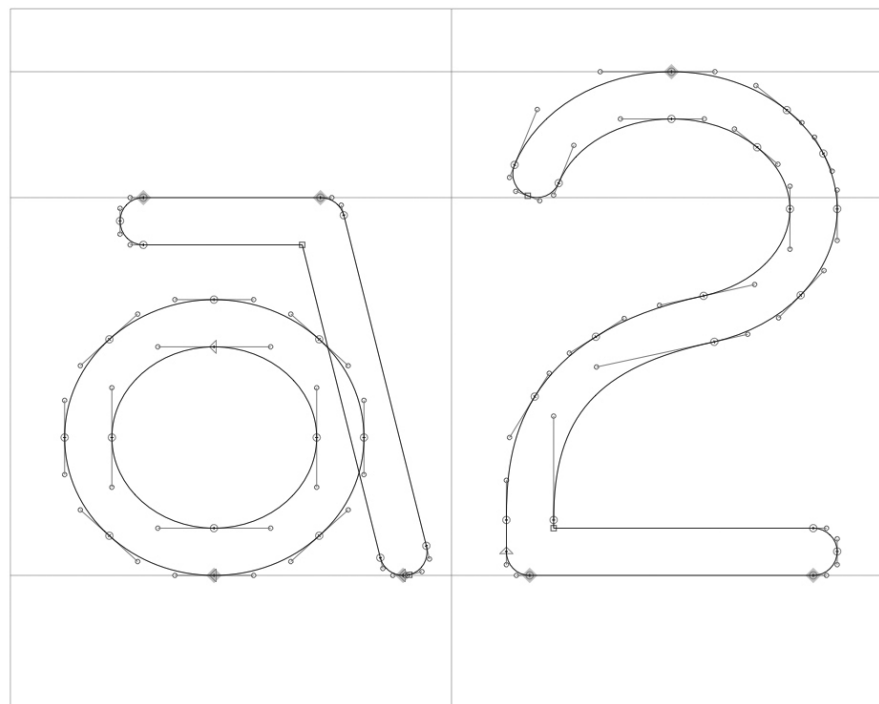

57-nao
TYPE SPECIMEN
P9/16

SAMPLES

Minor Martin White
(July 9, 1908 - June 24, 1976)

An American photographer, theoretician, critic and educator, White combined an intense interest in how people viewed and understood photographs with a personal vision that was guided by a variety of spiritual and intellectual philosophies. Starting in Oregon in 1937 and continuing until he died in 1976, White made thousands of black-and-white and color photographs of landscapes, people and abstract subject matter, created with both technical mastery and a strong visual sense of light and shadow. He taught many classes, workshops and retreats on photography at the California School of Fine Arts, Rochester Institute of Technology, Massachusetts Institute of Technology, other schools, and in his own home. He lived much of his life as a closeted gay man, afraid to express himself publicly for fear of loss of his teaching jobs, and some of his most compelling images are figure studies of men whom he taught or with whom he had relationships. He helped start and for many years was editor of the photography magazine Aperture.

ILOTT-TYPE

ilott-type.com
ilottvintage.com
info@ilottvintage.com
© 2015-16 ILOTT Vintage

HEAD 14/24pt
BODY 9/16pt

57-nao
TYPE SPECIMEN
P10/16

SAMPLES

ILOTT-TYPE

info@...

ilott-type.com
ilottvintage.com
info@ilottvintage.com
© 2015-16 ILOTT Vintage

90pt

57-nao
TYPE SPECIMEN
P11/16

SAMPLES

ILOTT-TYPE

```
<!DOCTYPE html>  
<html>  
<head>  
<meta charset="UTF-8">  
<title>57-nao</title>  
<meta name="description" content="monospace typeface" />  
<meta name="author" content="ILOTT®-TYPE" />  
</head>
```

57-nao
TYPE SPECIMEN
P12/16

SAMPLES

ILOTT-TYPE

Á Ă Â Ä À Ā Ą Å Æ

57-nao
TYPE SPECIMEN
P13/16

SAMPLES

ILOTT-TYPE

hauströkkrið yfir mér

ilott-type.com
ilottvintage.com
info@ilottvintage.com
© 2015-16 ILOTT Vintage

28pt

57-nao
TYPE SPECIMEN
P14/16

SAMPLES

ILOTT-TYPE

C R 2 5 8 ¥ ®
A N 6 3 9 £ ©
S L 4 1 7 € ™

ilott-type.com
ilottvintage.com
info@ilottvintage.com
© 2015-16 ILOTT Vintage

70/68pt

57-nao
TYPE SPECIMEN
P15/16

INSPIRATION
4 GLYPHS

ILOTT-TYPE

ilott-type.com
ilottvintage.com
info@ilottvintage.com
© 2015-16 ILOTT Vintage



1957-c.1982

57-nao
TYPE SPECIMEN
P16/16

ILOTT-TYPE



Ca*•n

ilott-type.com
ilottvintage.com
info@ilottvintage.com
© 2015-16 ILOTT Vintage